

**BERKELEY**  
**JET DRIVE**

**OVERHAUL  
SERVICE  
MANUAL**

## SERVICE MANUAL: BERKELEY JET DRIVES

### INDEX

- I. Introduction to jet drives.
  - A. About jet drives
  - B. Specific to Berkeley Jet Drives
  - C. Principles of operation
  - D. Dynamometer theory
  - E. Schematic
  - F. Impeller to engine matching
    - 1. Impeller curves
    - 2. Basic engine curves
    - 3. Match per operator requirement
    - 4. Variations for modified engines
  
- II. Trouble Shooting Check List
  - A. Excess RPM's
    - 1. Debris in jet
    - 2. Something in impeller
    - 3. Wear ring clearance
    - 4. Worn or dinged impeller
    - 5. High horsepower and big loads
    - 6. Air ingestion
    - 7. Loss of speed

- B. Loss of engine RPM's
  - 1. Fuel
  - 2. Engine tune
  - 3. Overheat
  - 4. Bad thrust bearing
  - 5. Something wrapped in shaft
- C. Loss of boat speed - constant RPM's
  - 1. Added operating weight
  - 2. Reverse gate drag
  - 3. Bottom spray drag
  - 4. Warped boat bottoms
  - 5. Dirty boat bottom
- D. Unusual noises
  - 1. Clatter or knocking sound
  - 2. Grinding or rubbing sound
  - 3. Squealing or high pitched rotating noise
  - 4. Hammering or thudding sensation
- E. Water leaks
  - 1. Packing gland
  - 2. Suction piece gaskets
  - 3. Transom adapter seal
    - a. Bowl to adapter
    - b. Adapter to transom
  - 4. Inspection cap/extension
  - 5. Cooling water hose
  - 6. Cable thru hull attachments

### III. Overhaul of Jet Drives

- A. Steering and reversing mechanism
- B. Impeller and wear ring
- C. Bowl/bowl bearing
- D. Suction piece/packing gland
- E. Shaft and bearing assembly

## I. INTRODDUCTION TO JET DRIVES

### A. About Jet Drives

The Jet Drive is Simple. A jet drive is a water pump, which is driven by a automotive engine that has been specially prepared for marine use. The engine is mounted within the hull and connected directly to the pump. There is no clutch or gear box.

The jet receives water through an intake grate in the bottom of the boat, and ejects the flow beyond the transom and through a steerable nozzle. The pump impeller, in ejecting the water, creates an equal force in the opposite direction which propels the boat forward. Steering is done by swinging the nozzle and rudder right or left, as desired.

The boat's attitude can be controlled by pointing the nozzle up or down within a controlled range on models with underway trim.

Reverse is accomplished by lowering a reverse gate across the outflow, diverting the jet stream forward, beneath the hull. Lowering the reverse gate when the boat is going forward, can stop the boat virtually within its own length. (Stopping should be done carefully to prevent passengers or free objects from being tossed forward.) There is no extra strain on the engine or the Jet-Drive when going from forward to reverse. The drive system can't detect the change; its rotation and load are not affected.

The jet drive does not know how heavy your boat is, or what speed the boat runs. Simply, the Berkeley jet drive in your boat is matched to the engine and will deliver about 1400-1800 pounds of thrust while pumping 3000 to 4000 gallons of water every minute at a pressure of 60 to 180 pounds per square inch (PSI).

### B. Berkeley Jet Drive Specifics.

The Berkeley jet drive is a mixed flow design (part axial flow, part centrifugal) with a 12" size designation. this 12" size designation is from water well sizing, meaning the bowl will fit in a 12" well casing. The original technology for Berkeley comes from the hydraulic principals used in the design of single through multi-stage line shaft turbine pumps which are used for submerged application in all types of water well or fluid transfer systems.

The balance of centrifugal and axial flow pump characteristics assures you of adequate thrust velocity for good performance in the popular boat speed ranges from 30 to over 60 MPH. The efficiency of the jet drive is readily seen once speeds in the 40 plus miles per hour ranges are reached. Minor changes in the nominal 3¼" diameter nozzle are possible and may be effective in fine tuning. Usually a slightly larger diameter for boats with top speeds below 45 MPH and a small decrease in nozzle diameter where speeds above 65 MPH are possible.

### C. Principals of Operation.

The jet drive should have been installed in your boat with a correct impeller to match the engine supplied with the jet drive. There is no requirement to change this impeller in an effort to increase out of the hole thrust or obtain better top speed.

Your jet drive is easy to maintain. There are few parts in a jet drive. The direct-drive shaft has a thrust and tail bearing. The impeller is fixed to the shaft and completely enclosed. The intake grate screens out most trash. . .but if tough weeds, string or a small rope pass the grate, and remain in the impeller, these are easily removed through a hand hole which is normally covered.

With no gears and so few parts, overhaul of a jet drive may not be necessary for several years, or hundreds of hours of use. Parts are largely interchangeable and readily available. Access is simple and there's a minimum of downtime.

The engine is heavy-duty automotive type, expertly modified for marine use. Maintenance is much the same as you would expect with a car.

Berkeley Jet Drives compare favorably with other types of propulsion on fuel consumption. Any engine uses excessive gas when pushed toward maximum RPM. At skiing speed a large V-8 can compare very favorable on fuel costs for a day of cruising, skiing and picnicking. Using the 12J, as an example:

With RPM reduced to 70% of maximum, fuel needed is reduced to only 32% of maximum, while speed is maintained at 66% of maximum.

Thus at two-thirds full speed, fuel use is cut to less than one-third, resulting in twice as many miles traveled per gallon. Since jets use ordinary automotive grade gasoline without expensive mixing with oil, by seldom exceeding 50 MPH you can have a day's fun for little, if any, greater cost than running a smaller I/O or outboard.

Because the Berkeley has more maneuvering ease than other drive systems, you should learn to handle your craft quickly and become an expert around the docks in a short time.

(See Page 23 for diagram)

A jet handles quite differently than the traditional prop and rudder. What makes a jet different, makes it better! It doesn't depend upon hull movement to attain full power. A prop unloads as forward speed is attained, which lets the engine rev to full power that is only available at full boat speed. With a jet, you hit the throttle and take off right now, with full power. When you reverse a jet drive, you reverse right now, with full power. When you turn, the jet, plus the rudder, swing you around in a super tight circle.

You can move a jet boat sideways into tight docking situations by switching from forward to reverse while coordinating the steering.

You will note one thing with the Berkeley Jet Drive which is totally different than other drive systems. If your Berkeley Jet Drive is not equipped with the standard (some models optional) rudder there will be no steering force exerted under a no throttle or engine off condition. This is not unsafe. Without underwater appendages, your jet drive propelled boat will immediately return to a straight line and coast to a stop if the power is cut quickly. Use of a rudder is recommended if you want to have more control, even under power off or low thrust conditions. You will learn to keep a little throttle on when slowing from high speed so you always have a power steering thrust force available.

#### D. The Dynamometer Theory

Your Berkeley Jet Drive operates in the same way a fluid dynamometer is used to measure engine output. Because the impeller horsepower curves supplied by Berkeley are very accurate, this curve will tell you the engine power being absorbed at any RPM.

You can look at the "B" impeller curve, for example, and see it requires 150 shaft horsepower (SHP) to turn 3800 revolution per minute (RPM). If you ski at 35 MPH and the engine must turn 3800 RPM, then you are using 150 SHP to drive your boat.

The Berkeley Jet Drive also measures absolute maximum SHP available from each impeller by absorbing all the power available at some RPM. As an example, you have a Berkeley Jet Drive with a high performance engine. If the impeller is an "A" trim and you can get 4700 RPM, then you are producing and absorbing 320 SHP.

Trouble shooting, using the dynamometer theory is very simple if you keep two principles in mind.

1. The impeller can never absorb more horsepower than shown on the impeller curve.

If you experience loss of RPM's your problem is either mechanical, i.e. seizing jet drive bearings or is in the engine.

2. The impeller absorbs less horsepower only when there is water flow interruption, wear or other causes which are not mechanical. Since the engine will not start making more power of its own accord, any increase in full-throttle RPM is an indication of pump wear, water flow blockage or air ingestion.

The rule is simple, RPMs up - look for wear, rocks in grate, ski rope in jet, etc. RPMs down - check thrust, tail shaft and universal joints for proper operation and look to the engine, fuel, spark, compression, etc.

#### F. Impeller to Engine Matching.

The following curve shows the horsepower absorption characteristics for a Berkeley 12J size jet drive.

1. Berkeley Impeller Chart
2. Engine to Berkeley Jet Drive Impeller Match

(See page 24)

In factory installed installations the impeller selected will provide the best average performance and is designed to keep the maximum engine RPM's possible well within safe operating limits.

You can obtain small increases in performance or tune the jet drive to your type or style of boating by making an impeller trim change.

If your engine is locked at 4200 RPM, let's say, and it will make power through 4800 RPM, then a smaller trim size for increased RPM should result in a higher top speed, providing the power gain was sufficient. In this situation you will need more RPMs at water ski and cruising speeds. You, however, may not care much about absolute top end and be much more interested in economy, quiet engines, strong low to mid range acceleration and the best water ski and cruise conditions. You would want to use a larger trim impeller and limit your top end RPM's. This set up will provide the most miles per gallon, a quieter boat, less engine wear and tear and will be more comparable to a typical stern drive setup. At 35 MPH the difference between an "AA" impeller at 3200 RPM (125 SHP) and a "C" impeller at 4900 RPM (140 SHP) is easily seen and felt.

These same two impellers would probably end up being 4200 RPM (280 SHP) and 5200 RPM (320 SHP) on the top end. You should apply these rules:

- a. Load the engines for best low and mid range performance.
- b. Unload the engines for higher top end RPM and speed, provided you have adequate horsepower gain.

4. Impeller matching (variations) for high performance engines.

Engine modification falls into two categories.

Changes which require higher RPM's in order to reflect a power gain. A few of these changes are higher lift, larger duration camshafts, higher compression, more or bigger carburetors. These modifications will provide more power, but are usually accomplished by increased RPM's and a torque curve which is moved 500 to 1000 RPM or more up the scale. If the impeller is too big you may be disappointed and discover you have worked hard and spent lots of cash to end up with little or no RPM gain or even lost RPM's.



As a rule of thumb, you should always decrease your impeller trim one size, i.e. "A" to "B" when going to a hotter cam. The jet drive needs lots of torque on the top end and very little below 3000 RPM so you must carefully match your new torque curve/HP curve to the impeller SHP absorption curve. If you also add cubic inches then an impeller size change may not be needed.

Engine modifications which are basically adding horsepower at the same RPM's, i.e. a blower, turbos, nitrous system, will either do well with the same impeller as stock and turn a few hundred more RPM's or will benefit from a larger trim impeller. Here are examples:

You turn 4600 stock and are at the peak of your stock horsepower curve. Addition of a nitrous kit might give you an additional 100 HP. Using the same impeller you will either gain 500 RPM and be off the cam curve or you can switch to a larger trim impeller to absorb the additional SHP at about the same RPM as before.

The alternative solution is to leave the impeller the same, change the cam and valve train to be more effective at higher RPM's and get a gross power gain which is the sum of the nitrous added power and effect of the stronger cam.

## II. TROUBLE SHOOTING CHECK LIST

### A. Excess RPM's

Using the jet drive as a dynamometer, excess RPM's must indicate one thing. Something is preventing the jet drive from absorbing the power available according to the Impeller Horsepower Absorption Chart. Here are the most common problems:

#### 1. Debris in the jet.

The boat takes a lot of RPM's to get or stay on plane, or may not get on plane at all. There may be accompanying vibrations or water thudding noises as well.

#### Cure

Shut down the engine. Remove the ignition key. Probe the intake area to see if something is hung in the grate. You will have to go overboard so first - try this; sometimes just shutting off the engine and restarting it will do the trick, especially if there are large weeds or a plastic bag sucked up against the grill.

If the slippage is still there and the grill is clear you probably have:

#### 2. Something in the impeller.

To inspect the impeller you will need to remove the hand hole cover. Use caution. Your jet may be below static water line. Remove the cover and you risk flooding the boat. If this is the case, beach the boat so it cannot sink or limp back to the trailer.

Invest in an extension for your inspection hand hole if it can be fitted.

Owners of transom mount "E" & "F" models are OK. Your hand hole is outside the boat. It may be difficult to get to, but there is no danger of flooding the boat.

Once the hand hole is open, feel all around the impeller for a small stick, piece of plastic, rock between the impeller blades or even ski ropes or long weeds wrapped around the impeller shaft.

Remove any debris you find, reinstall the cover and try to accelerate. If you are still slipping, you probably have something lodged way back in the impeller blades. Take another look!

Also check the impeller blades to see if there is a piece missing! This is very unlikely, but an ingested rock can break a blade.

### 3. Wear Ring Clearance

The wear ring acts as a seal between the high pressure water in the impeller, bowl area and the low or no pressure water in the suction piece.

if the wear ring is loose, there will be excess back flow of high pressure water and you will experience the following symptoms. Any or all of:

- a. Loss of a few MPH on the top end.
- b. Require more RPM's to maintain same cruise or ski speed.
- c. On hard acceleration, you will get several hundred RPM's overrun, then the engine will load back down to normal or slightly higher RPM's.

The only cure for a worn wear ring is disassembly of the bowl and impeller and replacement of the wear ring. Sometimes the impeller skirt (seal) area will be worn excessively as well.

### 4. Worn or Dinged Impeller

Operations in sandy, rocky or dirty water will cause the leading edge of the impeller blades to be dinged off. After awhile the edge is no longer almost sharp, but rounded off or even chipped or dented.

The symptoms of a worn impeller are the same as for a worn wear ring.

Diagnosis is simple. Feel the impeller blades through the hand hole or look at them through the grill with a flashlight to enable you to see the impeller.

If the edge is rounded, bumpy, chipped or has other damage, the impeller must be removed and either replaced or the edge rounded to its original contours.

Generally, an impeller overhaul and fitting of a new wear ring is all you will require to restore as before performance to your jet drive.

If your outfit was purchased used, and you have always had RPM's higher than the impeller curves indicate you should have, this simple overhaul may give you performance you never knew you had.

#### High Horsepower and Big Loads

Occasionally you will load up all your gear and crew in order to make one run to the campsite or across the lake. If you hit the throttle hard at low speed you may overpower the impeller and cause it to cavitate. Usually you can accelerate easily and get up on plane without over revving. If you cannot, either reduce your load or operate at suitably reduced throttle.

In the event you have a worn impeller or wear ring, sudden high RPM's at off plane boat speeds will induce cavitation much faster than when your jet drive is like new.

#### Operator Suggestions

Do not accelerate at sudden high RPM's when in shallow water. The suction will pull sand, mud, sticks, leaves or rocks into the jet and either promote rapid wear ring and impeller wear or leave you with debris in the impeller.

#### Air Ingestion

There are several types of air ingestion.

- a. The first air ingestion is caused by the impeller packing being worn loose. This air ingestion will be under high throttle acceleration. The suction of the impeller causes air to flow into the suction piece between the impeller shaft and packing.

A typical symptom of air ingestion of this type is high RPM's on acceleration which drop once the boat is at speed.

Usually worn packing will be indicated by leaking at the packing gland both at rest and at speed.

Replace the packing or tighten the packing gland.

- b. Certain boats will induce air ingestion at speed by funneling air down the edge of the keel, a strake, or past a thru hull fitting.

Air ingestion of this type is usually indicated by proper acceleration and load RPM's than an increase in RPM's with either loss of speed or no speed increase.

Sometimes a slight turn will make the tendency worse or performance may actually increase if the air stream is deflected away from the intake.

The remedy is to remove the air trap or modify the water flow down the boat bottom so this air is deflected towards the chines and away from the intake.

- c. At speed some boats become so loose and free running there is no hull in the water to make a smooth water flow, high pressure path for water to follow into the suction piece. The flatter the bottom (less dead rise) the sooner this problem will develop.

The symptoms are rapid and frequent momentary jumps in RPM's as the impeller grabs air, unloads, then grabs water and reloads. Aside from accelerated wear on the thrust bearing and impeller, the condition contributes to excess RPM's and blown engines.

If you operate on choppy or rough water at high speeds and experience this type of cavitation, you can either slow down, keep a very quick throttle foot or hand, install a RPM limiter set 200 to 400 RPM's above your normal RPM's or plan on bent pushrods, floated valves and broken connecting rods.

## 7. Loss of Speed

See items 1-2-3-4-5. If none of these account for the speed loss then look at these items.

- a. Reverse gate has slipped down and is dragging in the jet stream.
- b. You added weight to the boat. Speed is a power to weight relationship so every extra pound of fuel, gear or whatever costs a bit of speed.
- c. The bottom of your boat has changed due to trailer sag, broken bunkers, etc. and the boat will no longer ride as free as it originally did.

Restore speed by:

Losing weight.

Fix the trailer.

Straighten the boat bottom.

Adjust the reverse gate-shift cable linkage.

**B. Loss of Engine RPM's**

Again, remembering the dynamometer theory, loss of RPM is either due to loss of engine power or internal friction in the jet drive or drive shaft.

1. Poor fuel, water in fuel, old fuel, engine fuel system problems, plugged filters on fuel tank suction tube; check fuel flow!
2. Engine out of tune.
  - a. Check tuning, dwell, plugs, compression, etc.
  - b. Has the throttle linkage slipped so W.O.T. is no longer possible?
3. Engine is overheating.
  - a. Check for free water flow through the block. A garden hose on the inlet water line will let you see if you have water flow.
  - b. Is there water flow from the pump into the cooling hose? Leaves or gravel can get into the supply line. Clean it out.
  - c. Did the flow valve (if you have one) vibrate itself into the off or low flow position? Adjust it for proper flow then use a tie wrap to fix it so it cannot open or close.
  - d. Blown head gaskets or exhaust riser manifold gaskets can let high pressure gases into the engine cooling system. Check for water in the oil, water fouled spark plugs.
4. Bad Thrust Bearing

If the thrust bearing is failing or locking up the friction will pull the engine down.

Check if the bearing housing is hotter than usual. It should be cool or warm to the touch.

Listen for rotating noises such as squeaking, grinding or a rough vibration.

Note: A failed thrust bearing can lock up and you will twist the impeller shaft or it will let the impeller shaft ride forward and the impeller will eat itself up on the wear ring and suction piece.

The forward thrust can force the crankshaft forward and put excess strain on the main bearing thrust bearing.

If you suspect a bad thrust bearing, come home easy and save some big bills for parts other than a new bearing.

5. Something Wrapped in the Impeller Shaft

If you pick up lots of fishing line, a floating rope or your ski rope, it can wrap up and fill the suction piece cavity or get between the wear ring and impeller.

Remove the item through the hand hole opening using a sharp knife, hack saw blade, etc. to cut the mess loose. Sometimes it is necessary to pull the bowl and impeller.

C. LOSS OF BOAT SPEED - Constant RPM's

When you experience a reduction in boat speed, yet your full throttle RPM's are the same as before it is safe to initially assume there is nothing wrong with the jet drive, at least as far as it's internal condition is concerned. Once again, please remember the Dynamometer theory. The jet drive is absorbing the same power, at the same RPM's so it is putting out the same amount of thrust. Before you head off for a jet drive overhaul, take a look at these areas:

1. Have you added an extra fuel tank, started carrying two new sets of water skis, changed weight dramatically of any of your passengers or purchased a new 68 quart cooler? The speed of your jet boat is primarily a function of power to weight ratio - if you added weight, especially towards the bow, you will lose speed - a little or a lot, depending on how much weight and how it affects your craft's Longitudinal Center of Gravity (LCG).
2. Check your reverse gate and make sure it does not drag in the jet stream. Any drag is an application of reverse thrust and down goes your speed. Adjust your cable linkage, check for loose connectors, bent control pivot arms, loose bushings in the reverse gate pivot pins.
3. Bottom spray drag can also slow you down. Perhaps water is hitting the reverse chute since you raised your cavitation plate, or you installed a drop nozzle and now the whole steering section drags at speed.

4. A common cause of lost speed is the development of a hook in the running surface. Over a period of time trailers may sag, support bunkers break or one is knocked out of adjustment and the hull takes a new shape. If you get a hook in the last eight feet of running surface there will be a tendency for the hull to run flatter, move glued down, and the extra bottom drag slows you down.

The remedy is simple but involves lots of work, expense or both depending on how bad, who does the work and how exact you want the bottom blueprinted. Taking out a hook or straightening crooked running surfaces requires grinding off some of the high spots if possible, filling in the hollows and making a new straight surface for about the last eight feet of the boat bottom.

If you determine the trailer needs repair or adjustment as well, do it now or your newly straightened boat bottom will soon be crooked again.

5. A dirty boat bottom has resulted in speed loss or even the inability to get upon plane on many a boat. Boats left in the water grow weeds and algae and can loose as much as 10 MPH in only one week. A 200 mile tow on dusty roads, heavily traveled interstate or through a rain storm can leave enough road film on the running surface to scrub off an easy 5 MPH in a free running 70 MPH water craft.

#### D. UNUSUAL NOISES

If you are aware of the sounds normally heard when your boat is running, changes in sound will not only indicate potential problems, but help you diagnose the problem. Here are a few typical sounds:

1. Clatter or Knocking Sound
  - a. Check the U-joint very carefully. The needle bearing may be failing, need lube or the shaft splines may be dry.
  - b. Make sure the bolts tying the U-joint to the flywheel are tight. Loose bolts allow the U-joint flange to work and can allow the flywheel to spin loose from the crankshaft.
  - c. Check the tail shaft bearing by reaching in through the inspection hand-hole and feeling for up and down or side to side motion. There should be no discernible shaft movement.
2. Grinding or Rubbing Sound

If you see no visible cause for the grinding or rubbing sound and all the shaft bearings appear to have the correct clearances, it is a good precaution to pull the bowl and impeller. If a rock or other abrasive object is between the impeller and the wear ring or other parts of the jet drive assembly it can cause excess wear and cut the impeller apart, cut a groove in the bowl or suction piece or destroy the wear ring.

### 3. Squealing or High Pitched Rotating Noise

This type of sound almost always comes just before total failure of the thrust bearing. Another cause can be an object between the impeller and a non-rotating element of the jet drive.

If you detect this sound, check the bearing housing. It will get hot if you are about to lose a thrust bearing.

Come home slowly if you must. Remember, a failed thrust bearing can lock the shaft, let the shaft and impeller assembly spin in an uncontrolled arc. All of these items will do further mechanical damage and necessitate additional repair expense.

### 4. Hammering or Thudding Sensation

The water hammer or pounding sensation is usually caused by an object which is lodged in the blades of the impeller or between the bowl vanes.

Another cause is intermittent water flow disruption. A trailing bow rope that has an end whipping just inside the suction piece would be a good example.

A water hammer, if severe enough, for a long enough period of time can break the impeller, cause the bowl to crack or break open and may transfer uneven rotating stress back to the engine crankshaft.

If you experience such a sensation, shut down or go to idle RPM's immediately and determine the cause. Come home at slow speed if you cannot inspect the impeller or intake area while on the water.

Removal of the foreign object is usually all you will need to do. There is usually no mechanical damage unless the condition is extreme or you persist in high RPM operation.

## E. WATER LEAKS

There are only a few areas for water leaks on the jet drive and installation.

### 1. Leakage at the packing gland.

A very slow drip at idle is not bad, if the packing gland is too tight you can burn it so it will not seal. If the leak is excessive or you suspect an air leak under hard acceleration, tighten the packing gland just enough to eliminate the excess leak (more than 10/20 drops per minute at idle). If you cannot tighten the packing gland to eliminate the leak or you need excess bolt torque, the packing must be replaced. Don't panic, it can be done without a jet drive tear down or pulling the engine. See the overhaul section of this manual.



## 2. Leaks at the Suction Piece Gasket.

This can usually be eliminated by re-torquing the bolts. If you have to replace the gasket, the jet drive will have to be removed from the boat. See the overhaul section.

## 3. Transom Adapter Seal

- a. The transom adapter is sealed to the boat with a gasket. Apply a new bead of silicon around the joint as a first step repair or replace the gasket.
- b. The seal between the bowl and transom adaptor is either silicon, O-ring or both.

You can re-seal this area with more silicone sealer or pull the transom adaptor and replace the O-ring.

## 4. Inspection Cap/Extension

Water leakage and air induction are prevented by an O-ring. Keep the O-ring clean, free of sand and lightly lubricated. If the O-ring is cut, hardened or no longer an effective seal, replace it.

Do not over-tighten the cap bolts. You can warp the cap and it will not seal. Make sure the cap wrench is in place so the retainer bolts cannot work loose and allow the cap to be pushed out by water pressure.

## 5. Cooling Water Hose and Cable Thru Hull Seals

These areas and connections should be kept snug to prevent water leakage. Replace the water hose, cable seals, expansion boots every 3rd year as insurance against failure and a possible flooded boat.

### III. OVERHAUL OF JET DRIVE

It is essential you are familiar with section I an II of this manual. Proper trouble shooting will help you determine which parts must be removed from your jet drive, or the boat, in order to perform the necessary repairs or parts replacement. Starting at the back of the jet, outside the boat, all the parts for steering, reversing and trim control are accessible. Next you have the bowl and impeller assembly and wear ring and finally the suction piece, shaft and thrust bearing assembly and front packing gland assembly. With careful thought, you can do everything except replace the thrust bearing without taking the entire jet drive out of the boat. Only in rare instances should engine removal ever be necessary.

#### A. Disassembly (re-assembly of the steering and reversing mechanism)

In this assembly, all the parts are external and no seal between the jet drive and hull needs to be broken, unless you are replacing cable packing glands; items (#18, #15 and #16). See the transom housing parts illustration (#27). Normally repairs in this area will center around replacement of gasket (#17) and the 4 bushing (#29) page 7 on the lower pivot shaft, open steering shaft and the two reverse gate shafts.

1.
  - a. Remove the pins, (#55, #15 and #16 - 2 ea.) in order to separate the reverse gate from the steering nozzle and the steering nozzle and the steering nozzle (#6) from the nozzle housing (#5).
  - b. Remove the 5/16" × 1" socket head cup screw (#42) from the left and right reverse gate pivot shafts.
  - c. Push the pivot shafts into the steering nozzle until the reverse gate is free. Use of a solvent such as liquid wrench, WD-40 and a drift and hammer may be required where units have been in service a long time, especially in salt or brackish water.
  - c. Lift off the reverse gate, inspect and set aside for replacement, repaint or re-installation.
  - e. Remove 2 nylon bushing (#29) and inspect. Either replace or save if no wear or damage is apparent.
  
2.
  - a. Remove 5/16" × 1" socket head capscrew (#42) from lower steering pivot shaft.
  - b. Push shaft up into nozzle area. Be cautious the pin does not fall into the bowl and cause loss of time fishing it out. It is stainless steel so a magnet does not work.
  
3.
  - a. Remove the tiller shaft set screw (5/16" × 3/4 #43) using a 5/16 open end wrench. Note this set screw has a nylon lock button. The screws should always be replaced when it has been removed.
  - b. Remove upper woodruff key (#36) after removing tiller arm and push or tap the tiller shaft (#15) down through the nozzle housing.
  - c. Inspect the nylon bushing (#29) and discard if worn.
  
  - d. Inspect the woodruff keys (2 ea.) in the tiller shaft and the keyways in the nozzle (#6) and steering housing (#5). If the key way is worn your steering will be loose and steering failure is very possible. Replace either or both of items #5 & #6 if they are worn.
  - e. Inspect the O-ring (#20) on the steering nozzle and replace if damaged. A bad O-ring causes thrust loss around the nozzle (especially in turns) and excess water spray.
  
4. Use a 1/2" box end wrench or socket and ratchet to remove the 8 -5/16" × 3/4" capscrews (#51) which secure the nozzle housing to the after bowl face. Remove the nozzle housing and set aside the gasket (#17) for replacement.
  
5. Assembly is reversal of steps a. through j. Make sure all parts are serviceable, all threads are clean. Use a light grease such as Lubriplate on all moving parts to assure easy assembly and free movement.

Note: Check reverse gate and steering operation after re-assembly to insure full port to starboard steering and a full open reverse gate in the forward control position.

## B. BOWL AND BOWL BEARING

Other than introduction of fresh oil through the oil reserve plugs (#48), removal of the bowl is only required if you suspect foreign objects in the bowl vanes, loose bowl bearings, or you must remove the impeller.

1. Remove the transom housing (#1) by disconnecting the reverse gate cable, steering cable and transom housing retaining bolts. The housing is sealed using gasket (#6) and O-ring (#7). Most builders also are liberal with G.E. Silicone Sealant, so use of a large screwdriver, a wide stiff putty knife or rolling head pry bar may be necessary to break the transom housing loose from the boat transom and jet drive bowl.

If cable lengths permit, the housing may be slid aft and off the bowl. If the lengths do not permit, the cable seals must be loosened so the cables can be removed from the transom housing.

2. Remove the bowl by removing the 8 bowl to suction piece capscrews (#4) with a 3/4" box end wrench.
  - a. Separate bowl from suction piece and slide aft, off the impeller shaft.
  - b. Inspect bowl for damage to the bowl vanes, debris in the vanes, worn bowl bearings (#26) or bad seal (#28).

### Bowl Bearing Replacement

- a. Remove the end cap (#11) with a 15/16" box end wrench.
- b. Drive the bearings forward into the bowl using a bearing removal tool or any suitable drift which passes the bowl end cap threads and has a shoulder to seat on the bowl bearing.
- c. Drive first bearing (#26) into bore from the front side until the bearing face is flush with bore shoulder.
- d. Drive rear bearing (#26) into bowl from the back side until bearing face is flush with bore shoulder.
- e. Install bowl bearing end cap (#11) using Loctite (brown).
- f. Install lip seal in bowl counter bore with the lip facing forward. This seal does not keep oil in; it keeps debris and high pressure water out of the bowl bearing.

Note: Worn bowl vanes may be renewed by filling the dings and blunt edges off until there is a fine edge facing the water. The bowl vanes should be dressed so all the edges are the same distance from the front of the bowl.

### C. Impeller and Wear Ring

1. Remove the impeller nut (#32) using a 1 13/16" box end wrench or a 1 13/16" socket which has been modified so it will slip over the impeller shaft and has a holding handle welded on.

The impeller nut is a right hand thread and turns counter clockwise for removal.

Note: In cases where the impeller nut is frozen to the shaft due to extensive immersion in salty or chemically tainted water, it may be necessary to use a penetrating oil, apply heat, or even use a torch to cut the nut. Since the impeller shaft is stainless steel, careful application of a cutting torch will not damage the shaft or shaft threads. Use caution!

2. The impeller has a cast in groove on the hub. Use a puller with three or four inside jaws to grip the hub indent. Tighten the jacking screw and give it a blow with a ball peen hammer. It may be necessary to repeat this procedure several times before the impeller breaks loose. Liberal use of a penetrating oil may be required.

Note: The impeller fits on a straight shaft section with a long keyway. There is a shoulder on the shaft which the front of the impeller hub rests against when the impeller is fully seated.

3. Inspect the impeller for broken blades, cracks or excess wear on the wear ring seal area and dinged or chipped leading edges on the impeller blades.
  - a. The wear ring area may be dressed if there are grooves worn in it and a new wear ring sized to fit the smaller diameter.
  - b. Small nicks and dings or sand worn impeller blade leading edges may be renewed using a small die grinder, hand files and crocus cloth.

The proper blade shape is similar to an airfoil with the flat side on the top of the blade and the curved shape on the underneath side of the blade when you look at the impeller from the front. The edge should not be knife sharp, but finished to about a 1/32nd radius. Try to keep the leading edges of the blades all the same length.

4. Remove the wear ring & insulator (#13 & #14) from the suction piece by prying the parts out. This is facilitated with a small rolling head pry bar. You will remove the wear ring and the plastic liner.
  - a. Discard the wear ring and insulator if worn.
  - b. Install a new wear ring and insulator in standard or an undersized fit, according to the impeller eye size of your impeller. The wear ring should have rotating clearance only, when the impeller is installed.
  - c. Check final fit by slipping the impeller into the installed wear ring and rotating the impeller.
  - d. Re-check fit after the bowl is installed.

5. Reinstall the impeller in reverse order.
  - a. Use brown Loctite or Neverseize on the shaft and key, then slide the impeller onto the shaft with the key started into the keyway.
  - b. Use a tube type driver which fits over the impeller hub and seat the impeller tight against the shaft shoulder.
  - c. Install the impeller nut and tighten it to about 75 foot pounds or until the impeller is seated against the shaft shoulder.

Note: If you drive the impeller onto the shaft with excess force and the front of the shaft is not supported, your hammer blows will be transferred to the thrust bearing and small flats will be made on the ball bearing along with dents in the bearing races. Result: premature thrust bearing failure. The impeller should be a hand to light press fit on the shaft.

- d. Shaft and bearing assembly repairs or replacement are possible once you have removed the impeller and the suction piece is out of the boat, or the engine has been removed.
1. Removal of the entire jet drive or suction piece assembly only are preferable to pulling the engine.
    - a. Remove the suction piece assembly/pump assembly by removing the bolts and lock-wash (#5 & #6) page 28, which secures the suction piece to the intake housing which is fastened to the hull.
    - b. Pry up on the suction piece to break the gasket seal between the suction piece and the intake housing.
    - c. Slide the suction piece aft, out the access hole in your boat transom. The splined shaft will slip out of the U-joint which is fastened to the engine.

Note: 4 point engine mounts require no support for the engine. If you have a 3 point mount which rests on the suction piece housing, a suitable lift must be provided for the rear of the engine so the bell housing can be unclamped from the suction piece. It is advisable to install a wooden block between the hull and the engine bell housing to safely support the engine while the jet drive is removed.

2. Remove the bearing cap capscrew (#49 - 4 each) from the bearing housing and tap the bearing housing to remove it from the suction piece.
3. Remove the shaft and bearing assembly from the suction piece using a protective wood block or soft mallet and drive the shaft forward using a heavy hammer.
4. Remove the Tru Arc snap ring (#31) from the shaft.

5. Press the bearing from the shaft using a press or suitable mechanical bearing removal/installation tool. Support the bearing on the inner race while pulling it from the shaft if you plan to reuse it.
6. Inspect the shaft, especially the bowl bearing end and straightness in the spline through bearing fit areas. Repair or replace as indicated. Undersized bowl bearings are not available as factory replacement parts, so the shaft must be sized to original specifications. Use the undamaged forward area to obtain shaft diameter measurements.

E. Suction piece packing rings are removed easily once the shaft is removed.

1. Remove packing gland nuts (#39) and remove the split packing gland.
2. Pry out old packing rings (#23, set of 5) and slip new packing rings into place.

Note: Remove the packing rings in a similar manner if the shaft is in place. Use a packing puller, or make one with a long self tapping sheet metal screw. The packing rings are split for installation over the shaft. Make sure to stagger the splits in the rings in 90 degree intervals.

F. Reinstall the shaft and bearing assembly in the suction piece after installing the bearing on the shaft.

1. Install bearing so the thrust side (no groove for bearing balls) or side marked for inner race thrust is toward the shoulder on the impeller shaft. The thrust goes from the shaft shoulder to the inner bearing race and through the bearing balls to the front face of the outer race. The bearing housing cap (#8) absorbs the impeller thrust and clamps the outer race so it cannot spin or move fore and aft.
2. Slide the shaft and bearing into the suction piece and slide the bearing home by pressing or driving on the outer race only. Driving on the shaft will damage the thrust bearing resulting in premature bearing failure.
3. Tighten the packing gland lightly, just until there is slight drag on the impeller shaft. Final adjustment should be made with the shaft turning and the pump shaft submerged.
4. Refer to step C, item 5 for impeller reinstallation.

G. Reinstall the suction piece with shaft bearing and impeller/wear ring in the boat using a new gasket (#3) page 28. Installation of the suction piece assembly rather than the entire jet drive makes positioning the unit and shaft insertion into the splined U-joint easier.

Note: You may prefer to fully assemble the jet drive before installation. In this case, help from a second person or suspending the drive from the overhead may expedite getting the shaft splines into the U-joint and the suction piece aligned without gasket damage.

Note: You may find it helpful to use heavy grease or a gasket compound to help hold the gasket in place on the intake housing.

- H. Reinstall all components in the reverse order to their disassembly, making sure all seals between the boat and the jet drive are intact so there will be no leaks when you water test your boat.

Include all parts lists.

Special Notes:

1. All models of Berkeley jet drives are similar so only minor variation in assembly/disassembly are required.
2. Be especially careful of the rubber accordion boots used underwater on some models. A small puncture or tear will result in a flooded boat.
3. Berkeley "E" or insert model jet drives do not have an intake housing. The suction piece is bonded to the hull. Removal of the shaft and bearing assembly requires removal of the engine.

We would like to thank Jack Seastrom for his help with this manual. His knowledge and expertise were invaluable.

## Handles Differently

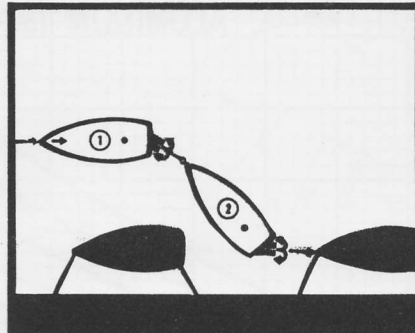
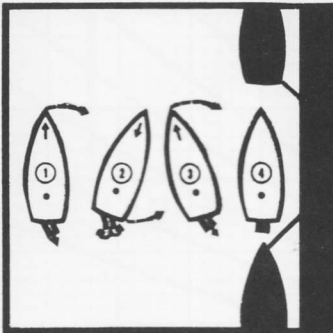

A jet handles quite differently than the traditional prop and rudder. What makes a jet different, makes it better! It doesn't depend upon hull movement to attain full power. A prop unloads as forward speed is obtained, which lets the engine rev to full power that is only available at full boat speed. With a jet, you hit the throttle and take off right now,

with full power. When you reverse a jet drive, you reverse right now. When you turn, the jet, plus the rudder, swing you around in a super-tight circle.

You can move a jet boat sideways into tight docking situations by switching from forward to reverse while coordinating the steering.





POWER DEMAND OF JET-DRIVE MODEL 12J

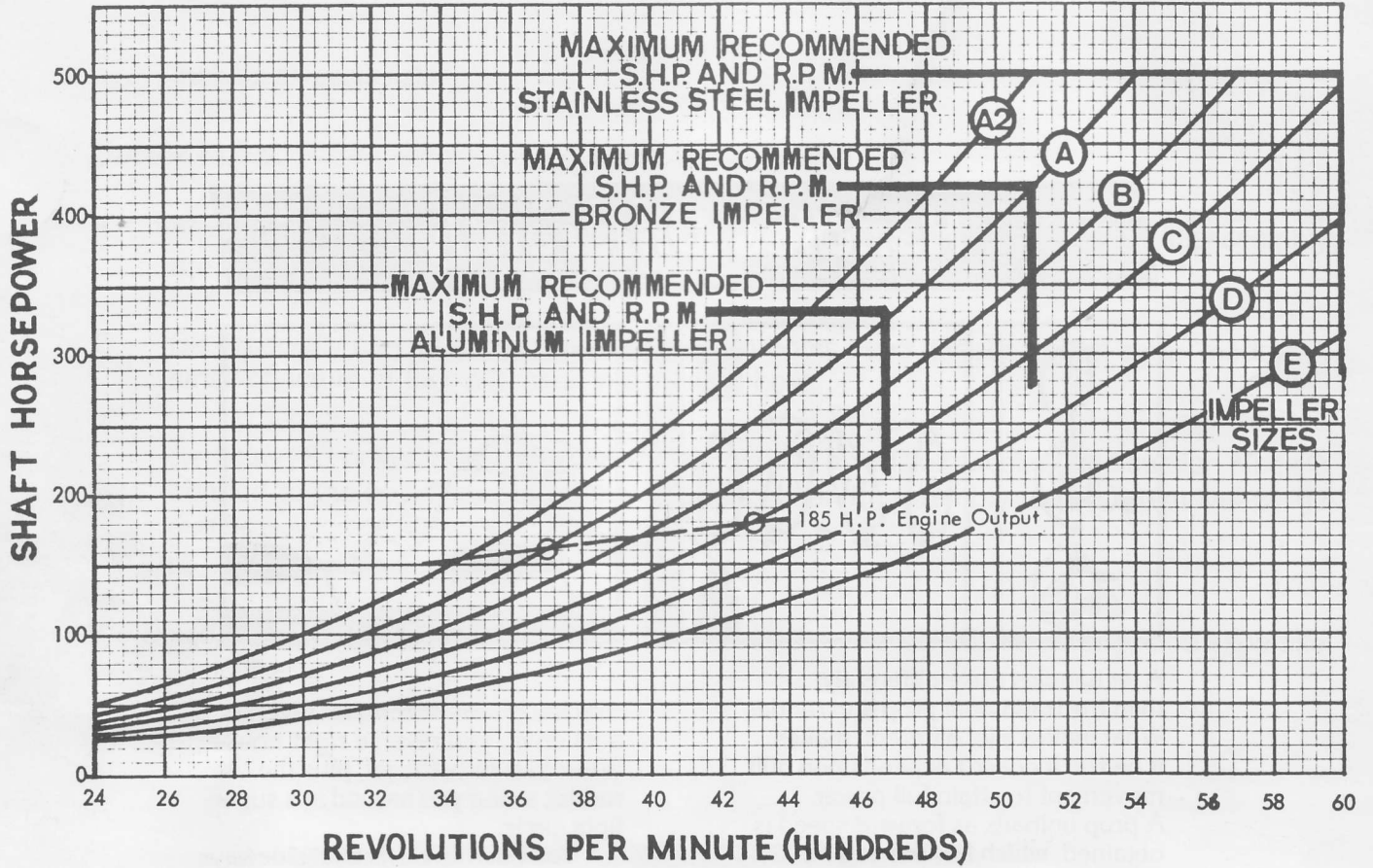

STANDARD SIZES A2 THRU E OF IMPELLERS

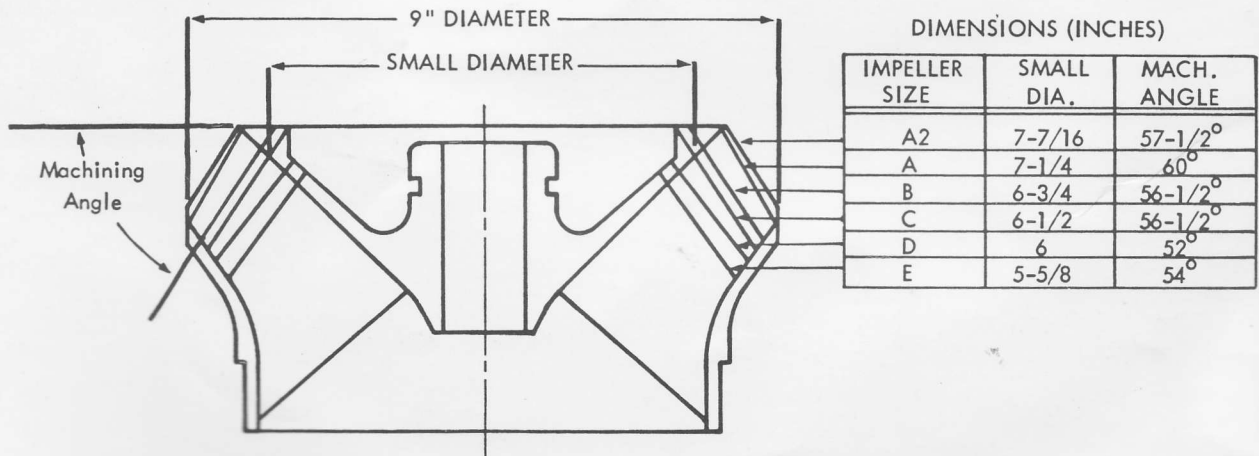
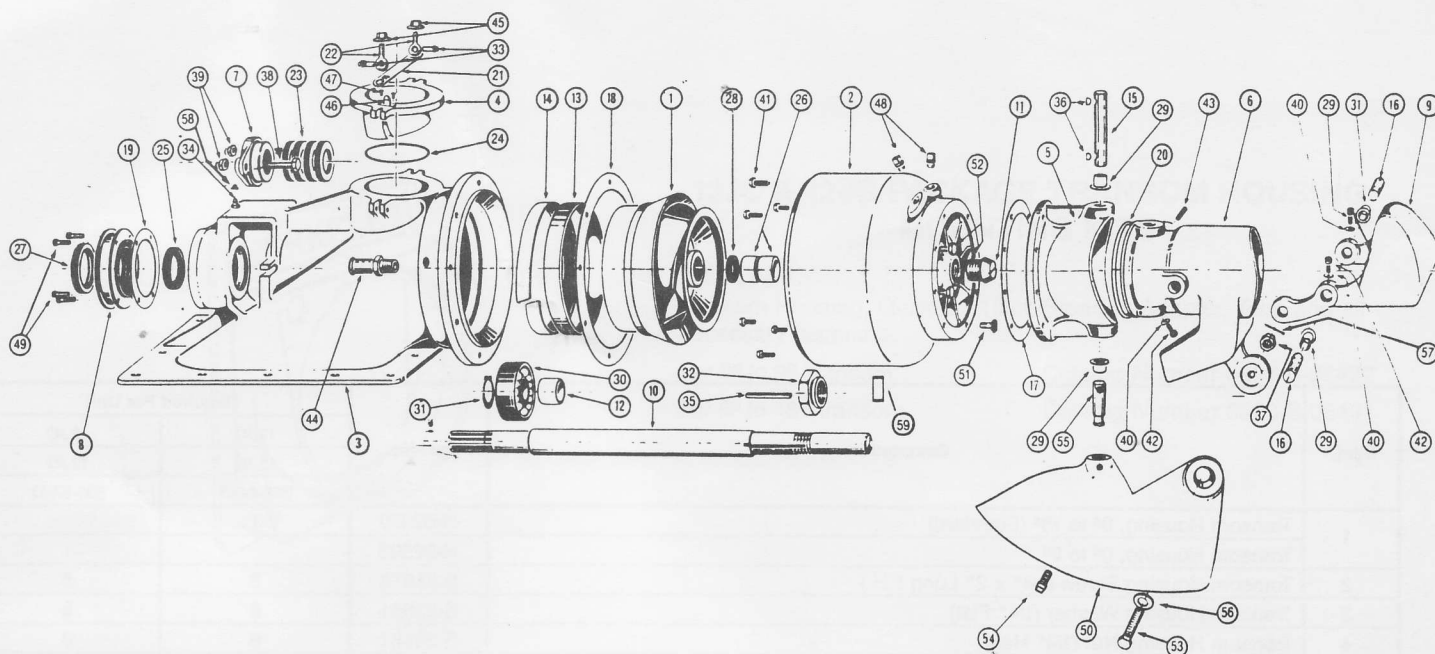

Figure 1

# 12JG Parts — BM-7338,



Sym.	Per Unit	Description	Part No.
1	1	Aluminum Impeller	L02507
	1	Commercial Stainless Impeller	L05021
2	1	Bowl	L03495
3	1	Suction Piece	H01727
4	1	Hand Hole Cover	M04128
5	1	Nozzle Housing	L05026
6	1	Nozzle	L04501
7	1	Packing Gland	S12727
8	1	Bearing Cap	S15338
9	1	Reverse Bucket	L04251
10	1	Pump Shaft	M05356
11	1	Bowl End Cap	S09850
12	1	Shaft Sleeve	S14379
13	1	Wear Ring	S10125
14	1	Insulator	S10068
15	1	Tiller Shaft	S15396
16	3	Rev. Bucket Shaft	S10825
17	1	Nozzle Hsg. Gasket	S10870
18	1	Bowl Gasket	S09017
19	1	Brg. Cap Gasket	S09018
20	1	Nozzle "O" Ring	S17737
21	1	Wrench	S11543
22	2	Rod End	S10907
23	5	Packing Rings	S08287
24	1	Hand Hold Cover "O" Ring	S13734
25	1	Suction Piece Seal	S14380
26	2	Bowl Bearings	S14483
27	1	Brg. Cap Seal	S14475
28	1	Bowl Seal	S14476
29	4	Nyliner Bearings	S14477

Sym.	Per Unit	Description	Part No.
30	1	Thrust Bearing	S14063
31	1	Snap Ring	S14478
32	1	Impeller Nut	S12005
33	2	Groove Pin	S14479
34	1	Grease Fitting	S14480
35	1	Impeller Key	S14482
36	2	Woodruff Key	S14481
37	1	Slotted Nut	S32400
38	2	Packing Gland Bolt	S23574
39	2	Packing Gland Nut	S26573
40	11	5/16 Lock Washer	S23088
41	8	Bowl Bolts	S23621
42	3	Nozzle & Rev. Bucket Capscrew	S25959
43	1	Set Screw	S23665
44	1	Barbed Connector	S14821
45	2	5/16 Hand Hole Nuts	S23680
46	1	Fastener	S14493
47	2	Fastener Screw	S25599
48	2	Oil Pipe Plugs S.S.	S13883
49	4	Brg. Cap Screws	S26151
50	1	Rudder Kit	B07486
51	7	Noz. Housing Capscrew Allen head	S25959
52	1	Noz. Housing Capscrew Allen head	S25958
53	1	Rudder Bolt	S32394
54	1	Set Screw	S23665
55	1	Rudder Pin	S16753
56	1	Washer	S23063
57	1	Cotter Pin	S26619
58	1	Grease Fitting Cap	S16549
59	1	Bowl Drain Plug	S13890

# 12JC & 12JG Package Transom Housing Mounting Kits BM-6491, BM-6492

Sym.	Description	Part No.	Required Per Unit	
			12JC	12JC
			12JG	12JG
			BM-6491	BM-6492
1	Transom Housing, 9° to 18° (Standard)	H-02079	1	
	Transom Housing, 0° to 9°	H-02503		1
2	Transom Housing Screw (1/4" x 2" Long F.H.)	S-25672	8	8
3	Transom Housing Washer (1/4" Flat)	S-23061	8	8
4	Transom Housing Nut (1/4" Hex)	S-23481	8	8
5	Transom Housing Screw, #14 Sheet Metal x 1" Lg.	S-26413	2	2
6	Rubber Gasket for Transom Housing	S-13166	1	1
7	Bowl Seal "O" Ring	S-13731	1	1
8	Tiller	M-05645	1	1
9	Tiller Set Screw (5/16"-18 x 3/4" Lg. Sq. Hd. Set Screw)	S-23665	1	1
10	Reverse Cable Adjusting Nut (BM-6592)	S-15413	2	2
11	Retaining Clip (BM-6592)	S-16609	1	1
12	Reverse Control Arm Pin (BM-6592)	S-15412	1	1
13	Nyliner Bearing (BM-6592)	S-15414	2	2
14	Reverse Cable Packer Nut (BM-6593)	S-15426	1	1
15	Reverse Cable Packer Washer (BM-6593)	S-15427	2	2
16	Reverse Cable Packer Grommet (BM-6593)	S-09488	1	1
17	Steering Tube Nut (7/8")	S-13530	2	2
18	Steering Tube Bushing	S-13531	1	1
19	Steering Adapter Tube — Morse Steering Only	S-15383	1	1
	Steering Adapter Tube — Rideguide & Teleflex	S-13965	1	1
	Steering Adapter Tube — Steermaster & Marmac	S-13529	1	1
20	Adapter — Steermaster Steering Only	S-13665	1	1
21	Capscrew, Str. to Tiller — Morse & Rideguide	S-32364	1	1
22	Spacer Nut, Str. to Tiller — Morse & Rideguide	S-26457	1	1
23	3/8-24 Nylock Nut	S-26431	1	1
24	Drain Plug (B-07572)	S-16238	1	1

# 12J Parts — BM-6491, BM-6492



## 12JC & 12JG PACKAGE TRANSOM HOUSING MOUNTING KITS

Transom Housing, Gaskets, Tiller, Steering Adapter, Tube and all necessary fasteners.

For 0° to 9° Transom

Catalog Number 0203-B-06492

For 9° to 18° Transom

Catalog Number 0203-B-06491

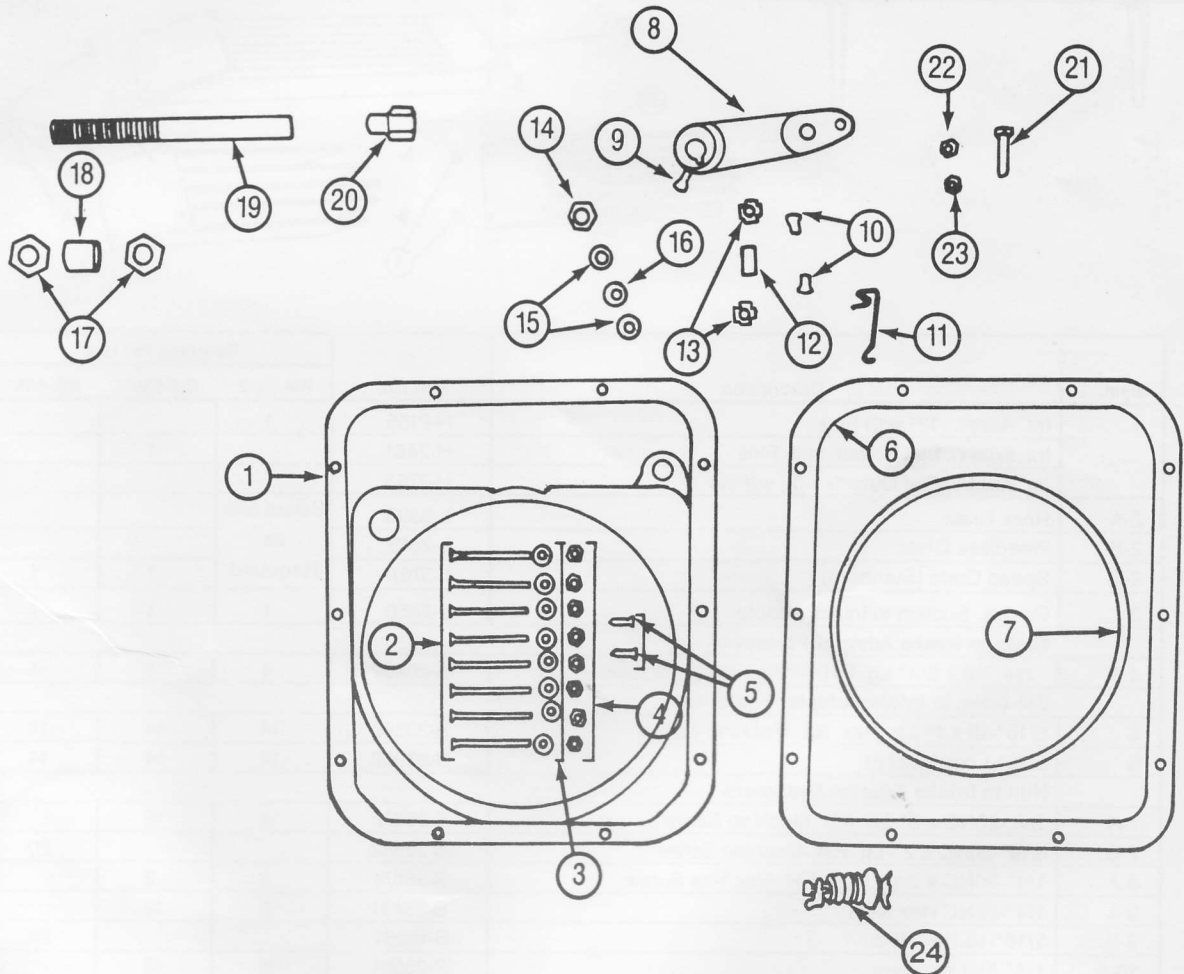

# 12J Package Intake Adapter Mounting Kits BM-5812, BM-6309, BM-6667

## INTAKE ADAPTER MOUNTING KITS

Includes Intake Adapter, Grate, Gasket and all necessary fasteners.

Flat Inside Mount with Fins and Flat Head Machine Screws (1)  
Catalog Number 0203-B-06309

12-degree with fins and Flat Head Machine Screws (2)  
Catalog Number 0203-B-05812

Flat Outside Mount with fins and Flat Head Machine Screws (5)  
Catalog Number 0203-B-06667

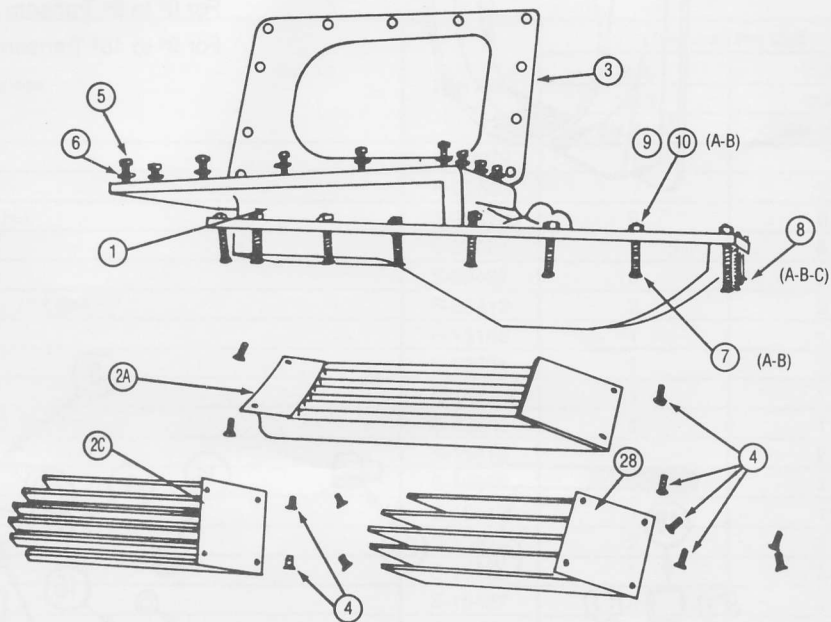
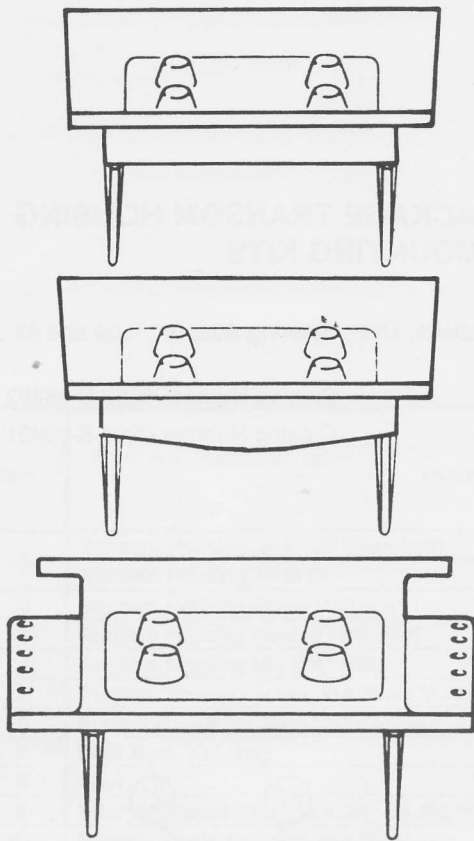

Sym.	Description	Part No.	Required Per Unit		
			BM-5812	BM-6309	BM-6667
1	Int. Adapt., 12° with Fins	H-2155	1		
	Int. Adapt., Flat Bottom with Fins	H-2481		1	
	Int. Adapt., Flat Outside Mt., w/Fins	H-2768			1
2-A	Rock Grate	L-3306	Select one as Required		
2-B	Weedless Grate	L-2818			
2-C	Speed Grate (Standard)	L-3767		1	1
3	Gasket, Suction to Intake Adapter	L-2850	1	1	1
<b>Grate to Intake Adapter Fasteners</b>					
4-A	1/4"-20 x 3/4" Lg. F.H. Philips Taptite Screws	S-26402	4	4	4
<b>Jet-Drive to Intake Adapter Fasteners</b>					
5	5/16"-18 x 1" Lg. Hex. Hd. Machine Screw	S-23540	14	14	14
6	5/16" Lock Washer	S-23088	14	14	14
<b>Hull to Intake Adapter Fasteners</b>					
7-A	1/4"-20NC x 2" Lg. F.H. Machine Screw	S-25672	14	16	
7-B	5/16"-20NC x 2" Lg. F.H. Machine Screw	S-25682			20
8-A	1/4"-20NC x 2-1/2" Lg. F.H. Machine Screw	S-25674	2	2	
9-A	1/4"-20NC Hex Nuts	S-23481	16	18	
9-B	5/16"-18 Hex Nuts	S-15981			20
10-A	1/4" Flat Washers	S-23061	16	18	
10-B	5/16" Flat Washers	S-23062			20